

# GLEASON **PowerTrak**®

## “L”-Type Steel Cable/Hose Carrier

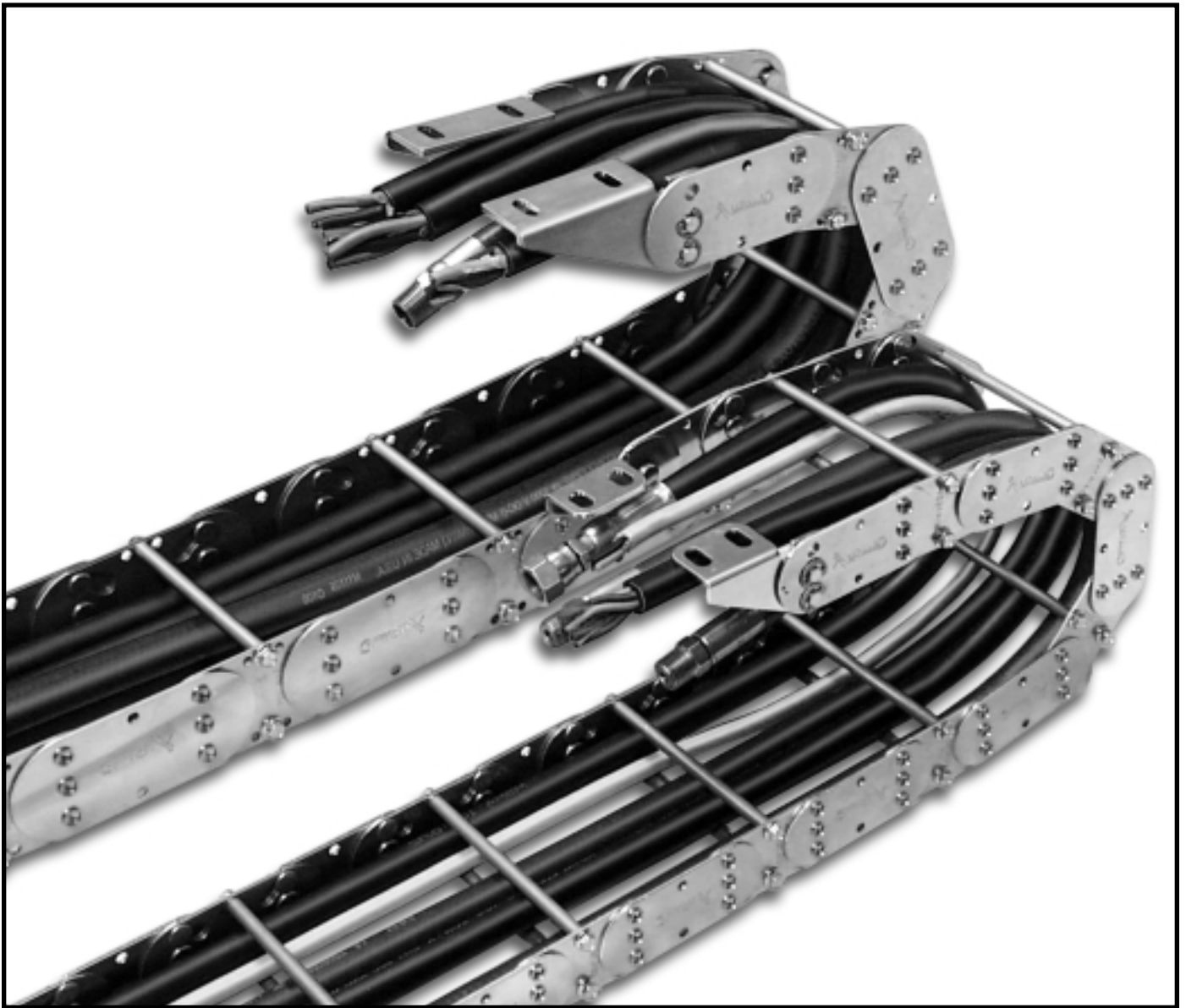

**POWERTRAK MODELS PT16L and PT26L**

PTL0599

- GENERAL DUTY
- HIGH STRENGTH, LOW ALLOY STEEL
- L-TYPE™ SINGLE PLATE LINKS

- MAX TOTAL TRAVEL = 16.0 FT.①
- MAX SPEED = 200 FPM
- MAX ACCELERATION = 5.0 FT/SEC<sup>2</sup>
- MAX CABLE/HOSE O.D. = 0.63 IN
- POWERTRAK WEIGHT UNLOADED = 1.1 LBS/FT.②

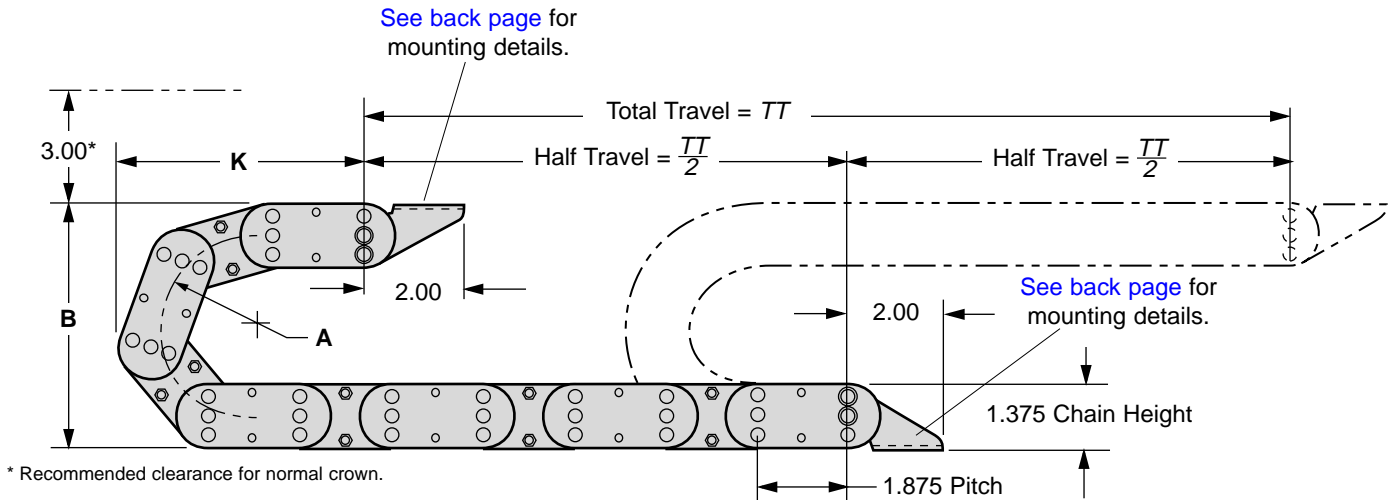

Required length (ft) ③ =

$$\frac{TT}{2} + L^{④}$$

Round UP to nearest ODD number of links.

RADIUS A	HEIGHT B	MIN. K	CURVE L <sup>④</sup>
2.06	5.50	5.51	1.0 ft.

#### NOTES:

- ① Based on standard travel with a cable/hose package weight of 1.00 lbs/ft.
- ② Based on average carrier weight @ 6.00" width.
- ③ Based on standard travel, i.e. two-way payout as pictured above.
- ④ Minimum length in FEET required to form PowerTrak curve.

## Model Number Explanation

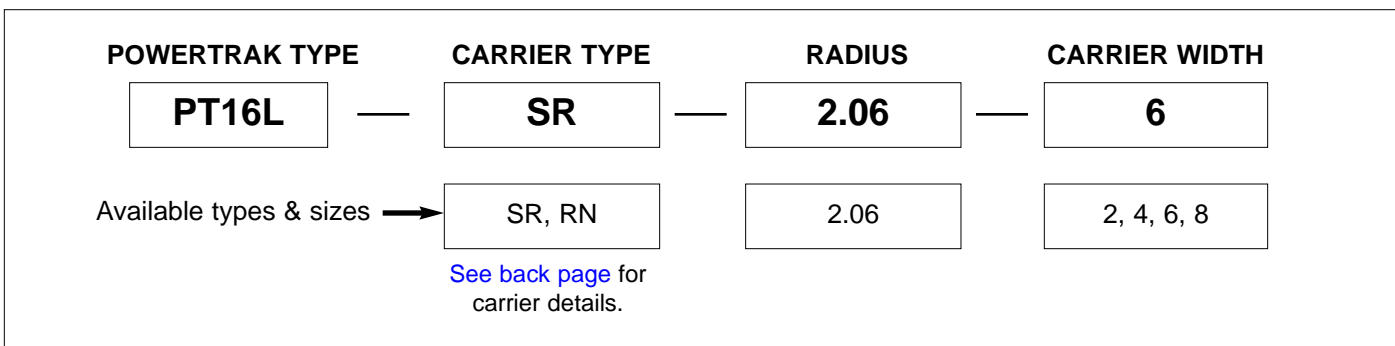

- GENERAL DUTY
- HIGH STRENGTH, LOW ALLOY STEEL
- L-TYPE™ SINGLE PLATE LINKS
- STANDARD OR CUSTOM RADII

- MAX TOTAL TRAVEL = 20.0 FT.①
- MAX SPEED = 200 FPM
- MAX ACCELERATION = 5.0 FT/SEC<sup>2</sup>
- MAX CABLE/HOSE O.D. = 1.12 IN
- POWERTRAK WEIGHT UNLOADED = 1.95 LBS/FT.②

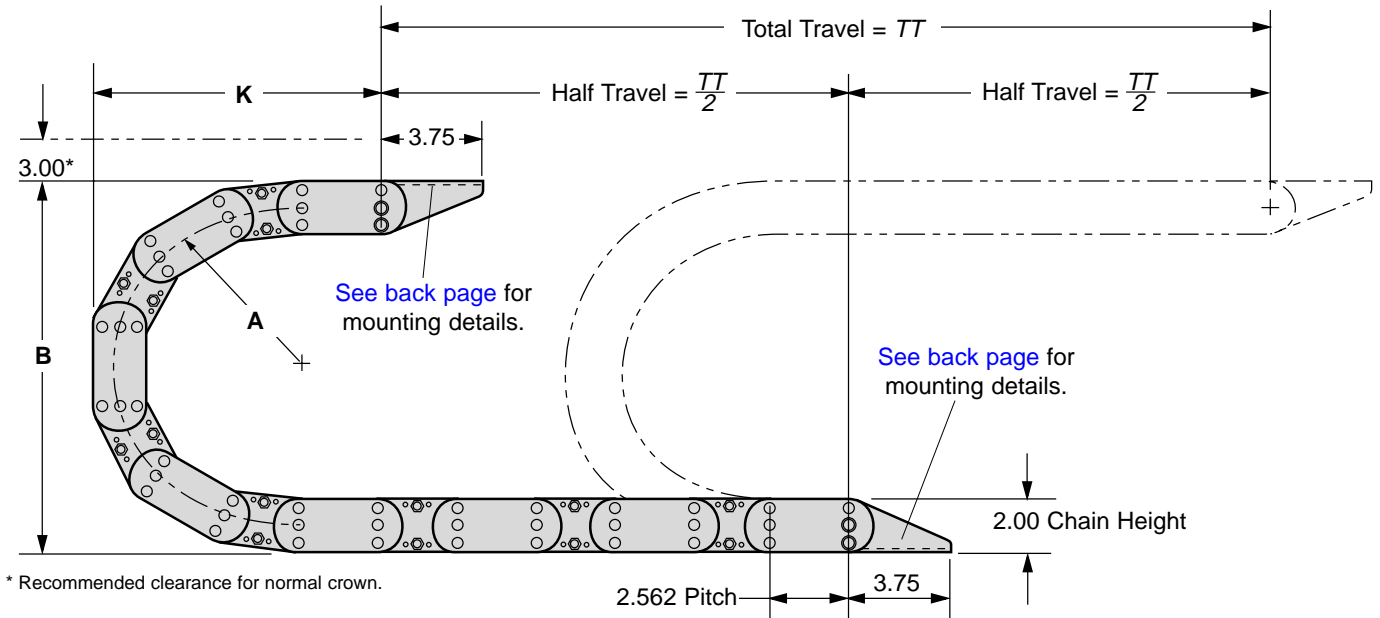

Required length (ft) ③ =

$$\frac{TT}{2} + L^{④}$$

Round UP to nearest  
ODD number of links.

RADIUS A	HEIGHT B	MIN. K	CURVE L <sup>④</sup>
2.75	7.50	5.43	1.0 ft.
4.53	11.06	7.41	1.5 ft..
5.63	13.26	9.79	2.0 ft..

**NOTES:**

- ① Based on standard travel with a cable/hose package weight of 2.00 lbs/ft.
- ② Based on average carrier weight @ 6.00" width.
- ③ Based on standard travel, i.e. two-way payout as pictured above.
- ④ L = minimum length in FEET required to form PowerTrak curve.

## Model Number Explanation

POWERTRAK TYPE	CARRIER TYPE	RADIUS	CARRIER WIDTH
PT26L	SR	2.75	6
Available types & sizes	SR, RN, R1	2.75, 4.53, 5.63	4, 6, 8, 10, 12

See back page for carrier details.

# PT16L Carrier Types & Dimensions

Dimensions in Inches

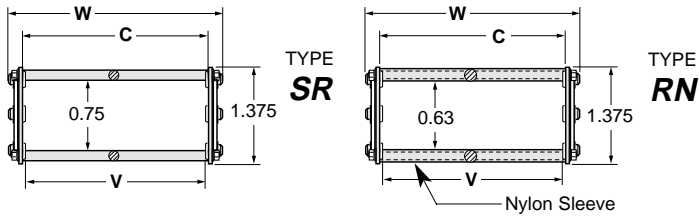

CARRIER WIDTH C	USABLE WINDOW OPENING V	POWERTRAK WIDTH W
2"	1.91	2.40
4"	3.91	4.40
6"	5.91	6.40
8"	7.91	8.40
Formula	$C - 0.09$	$C + 0.40$

## Mounting Brackets

Dimensions in Inches

CARRIER WIDTH C	FEET TURNED IN <sup>①</sup>		FEET TURNED OUT <sup>①</sup>	
	MOUNTING LOCATION E ± .12	OVER BRACKETS F	MOUNTING LOCATION G ± .12	OVER BRACKETS H
2"	0.97	2.16	3.22	4.07
4"	2.97	4.16	5.22	6.07
6"	4.97	6.16	7.22	8.07
8"	6.97	8.16	9.22	10.07
Formula	$C - 1.03$	$C + 0.16$	$C + 1.22$	$C + 2.07$

① Brackets may have flanges inward (standard) or outward (optional)

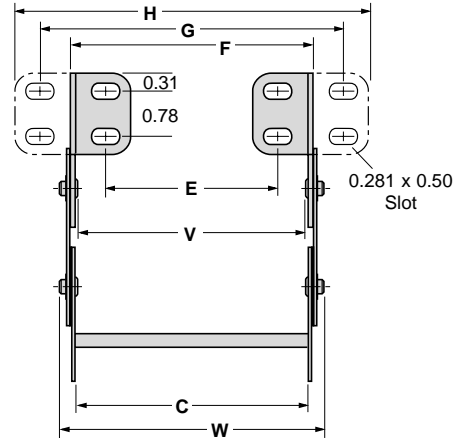

# PT26L Carrier Types & Dimensions

Dimensions in Inches

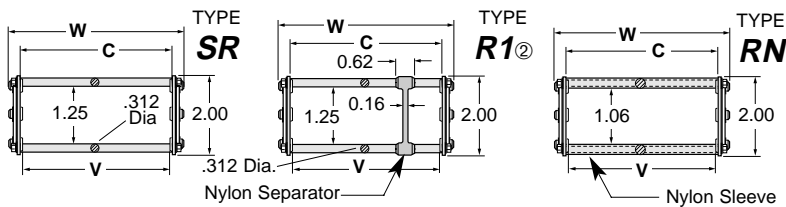

CARRIER WIDTH C	USABLE WINDOW OPENING V	POWERTRAK WIDTH W
4"	3.87	4.49
6"	5.87	6.49
8"	7.87	8.49
10"	9.87	10.49
12"	11.87	12.49
Formula	$C - 0.13$	$C + 0.49$

## Mounting Brackets

Dimensions in Inches

CARRIER WIDTH C	FEET TURNED IN <sup>①</sup>		FEET TURNED OUT <sup>①</sup>	
	MOUNTING LOCATION E ± .22	OVER BRACKETS F	MOUNTING LOCATION G ± .22	OVER BRACKETS H
4.00"	3.00	4.19	5.34	6.33
6.00"	5.00	6.19	7.34	8.33
8.00"	7.00	8.19	9.34	10.33
10.00"	9.00	10.19	11.34	12.33
12.00"	11.00	12.19	13.34	14.33
Formula	$C - 1.00$	$C + 0.19$	$C + 1.34$	$C + 2.33$

① Brackets may have flanges inward (standard) or outward (optional).  
 ② Numeral "1" refers to the number of vertical separators desired and must be included in the model number when ordering. Examples: R1 (above), R2, R3, etc.

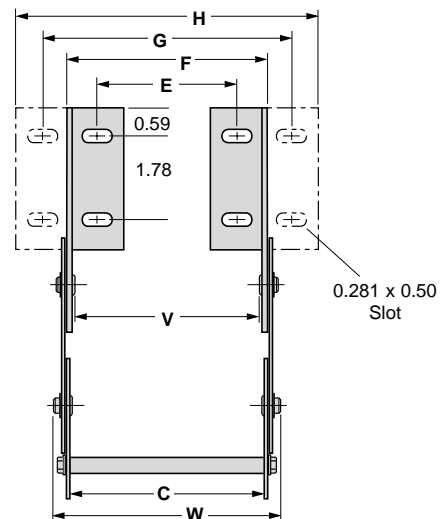

## Brake Products, Inc.

16751 Hilltop Park Place  
 Chagrin Falls, OH 44023  
 Phone: (888) 861-8777 • Fax: (440) 543-7963