



R45 Series

Spring-Operated Quad Hose Reels for Hydraulic Lift Trucks

Gleason's unique four port design improves operator visibility, increases reel efficiency and provides substantial cost savings.

Thanks to quad porting, the R45 Series reduces the number of hose reels required for hydraulic service on lift trucks. Instead of multiple reels, only one quad unit is necessary. The result: Improved visibility, greater operational safety and reduced cost.

The R45 Series spring operated quad hose reels provide design simplicity and compactness, installation and replacement ease, and dependable, long service life. These rugged reels are available with capacities to 17 feet of #4 hose and for pressures up to 2000 PSI. They also feature a new seal design and kink-free hose entrance.

Additional R45 Series features include:

- All steel construction.
- Exclusive narrow spool design for operation in tight quarters.
- Extra heavy spring motor for positive response.
- Integral hose ramp for smooth transition from steel spool into manifold area...eliminating sharp corners.
- Safetychange® replaceable spring motor.
- Long life main spring with declutching feature.
- Full pressure and flow under continuous rotation.
- Seals in quad port swivel suitable for use with petroleum base fluids. Seals also available for use with phosphate ester base fluids.
- Available in either Right Hand or Left Hand configurations
- Baked polyester finish.



"Goose-necks" plus integral ramp assure smooth hose transition between manifold and reel spool.

R45 Quad Hose Reel Engineering Data

DIMENSIONS

R45

(RH SHOWN...LH OPPOSITE)

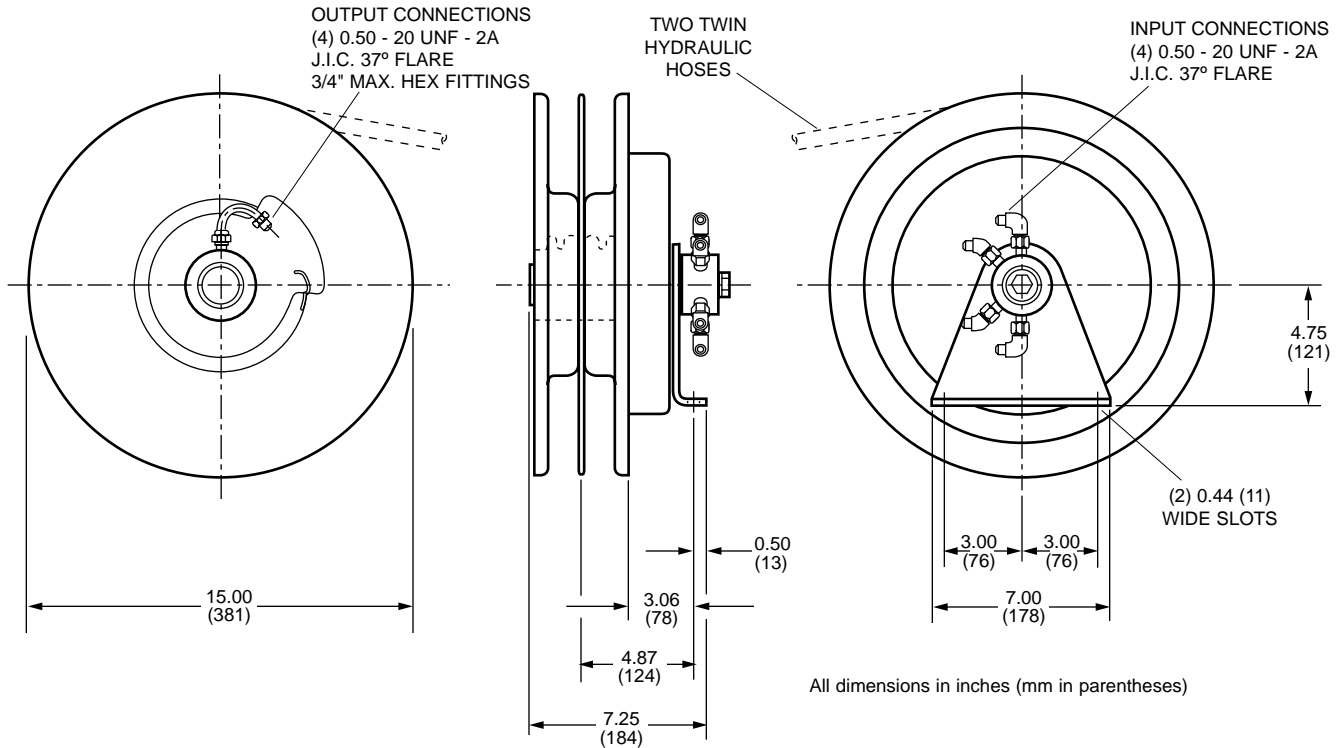

MODEL CHART

MODEL NO.	HOSE DESCRIPTION	MAX. PRESS.	LENGTH
Model R45-RH-15	(2) 1/4" I.D. twin hydraulic	3000 psi	17 ft. long
Model R45-LH-15	(2) 1/4" I.D. twin hydraulic	3000 psi	17 ft. long

HOSE NOT INCLUDED, but may be ordered separately and factory installed. See you local Gleason Reel Representative.



Brake Products, Inc.

16751 Hilltop Park Place
Chagrin Falls, OH 44023
Phone: (888) 861-8777 • Fax: (440) 543-7963
www.brakeproducts.com

Represented by: