



# T-50 Curved Rail Festoon System

Heavy duty festoon system follows your machinery or conveyor line. Supplies electric power or compressed air, where needed, when needed.



Unique eight wheeled trolleys glide smoothly around curves or along straight sections.

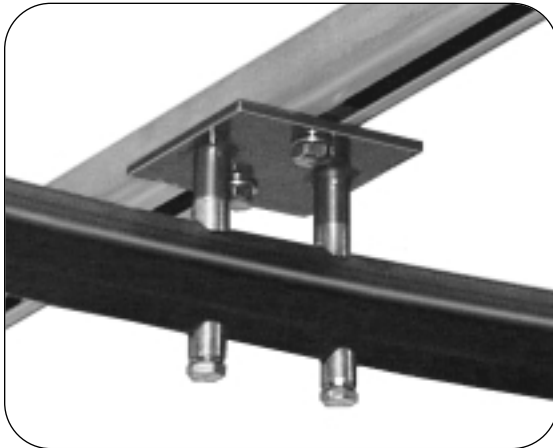

Sturdy hanger system makes custom installation quick and easy. Curved rail sections are available with 36" to 340" radii. Straight sections also available.

Trolleys and stationary end stops (right) designed to handle flat or round cables/hoses. See inside for cable and hose sizes and detailed drawings of all components.



# Rail, Hanger Brackets & Accessories

T-50 rail sections are available in a wide range of sizes and radii to accommodate virtually any festoon layout. All rail is high strength steel with an oil film finish. Stainless steel is also available...consult factory for details. Special consideration must be given regarding loop depth and length of tow chain or tow rope (required). Consult factory for guidelines. When ordering, please submit detailed layout sketch

**CURVED RAIL SECTION MODEL NUMBER:** T50-TR-CR-(radius)-(degrees)

*Example: T50-TR-CR-120(radius)-45(degrees of arc).* See chart below.

Note that rail with 120" radius requires two sections to complete 90° arc.

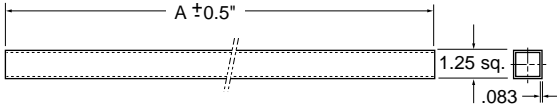

## Straight Rail

MODEL NO.	LENGTH "A"	WEIGHT Lbs.
T50-TR-05	5.0 ft.	6.6
T50-TR-10	10.0 ft.	13.2
T50-TR-20	20.0 ft.	26.3

## Curved Rail

RADIUS in.	Qty. Pieces to make one 90°	Quantity Couplers
36.0 – 68.0	1	0
69.0 – 136.0	2	1
137.0 – 204.0	3	2
205.0 – 272.0	4	3
273.0 – 340.0	5	4

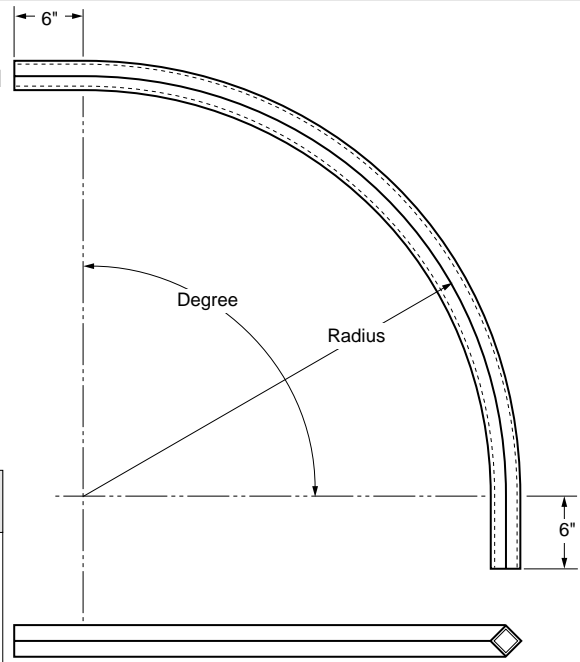

## Hanger Bracket

**Model Number:** T50-HB-Z

**Purpose:** Support curved or straight rail sections. (See chart below for maximum spacing along rail.)

**Material:** Zinc plated steel. All hardware included.

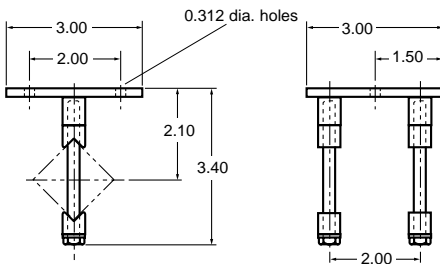

## End Stop Hanger Bracket

**Model Number:** T50-ES-Z

**Purpose:** Support curved or straight rail sections at end(s) of open system. Prevents trolleys from running off track. Essential on hand pulled system.

**Material:** Zinc plated steel. All hardware included.

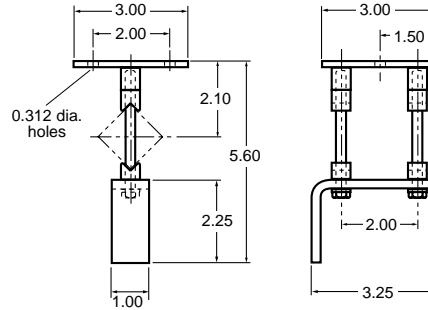

## Maximum Hanger Bracket Spacing

Load per Trolley (lbs.)	Center-to-center Distance (in.)
50	48
40	51
30	54
20	60
10	72

## End Cap

**Model Number:** T50-EC

**Purpose:** Closes rail ends.

**Material:** Black vinyl.

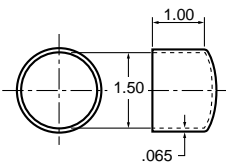

## Joint Coupler

**Model Number:** T50-CP-Z

**Purpose:** Joins rail sections and provides smooth transition at joints.

**Material:** Zinc plated steel. Hardware included.

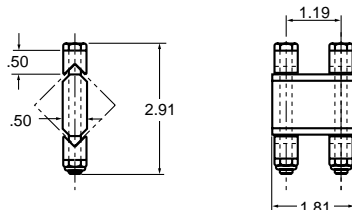

## Drill Jig

**Model Number:** T50-DJ

**Purpose:** Required to locate and drill holes diagonally thru rail for hangers, end clamps, couplers, etc.

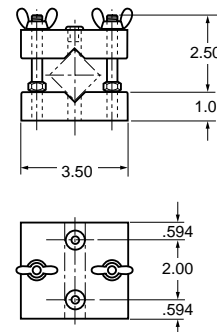

# Trolleys and Accessories for Round Cable/Hose

T50 round cable/hose festoon systems are available in two styles...clips (top) and saddles with clamps for multiple cables (bottom).  
All components orange baked polyester coating. All hardware zinc plated.

**Maximum load capacity: 50 lbs. per trolley.**

## Intermediate Trolley with Clip

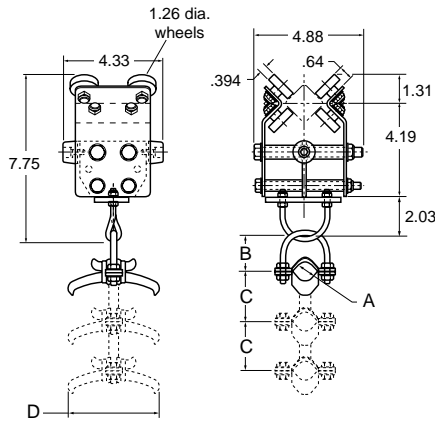

## Tow Trolley with Clip

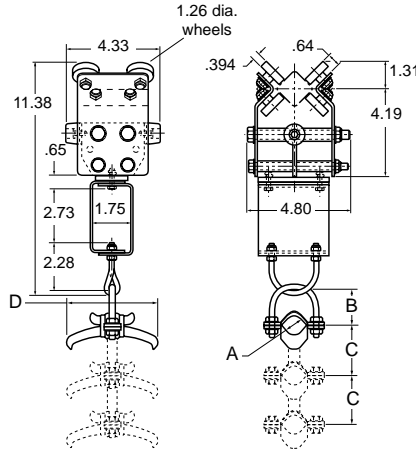

## End Clip

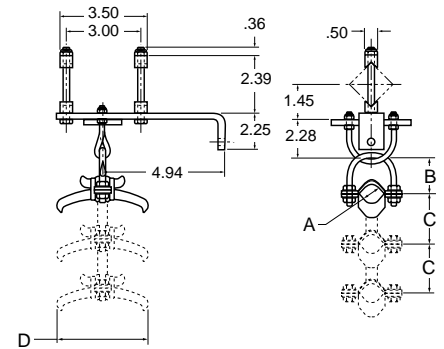

MODEL NUMBER	NUMBER OF TIERS	CABLE/HOSE O.D. RANGE	CABLE CENTERS	CLIP LENGTH
W/STANDARD HARDWARE	A	B	C	D
T50-C111-Z-S	1	0.31 - 0.59	4.25	2.75
T50-C121-Z-S	1	0.60 - 0.94	4.38	3.86
T50-C211-Z-S	2	0.31 - 0.59	4.25 1.31	2.75
T50-C221-Z-S	2	0.60 - 0.94	4.38 1.88	3.86
T50-C311-Z-S	3	0.31 - 0.59	4.25 1.31	2.75
T50-C321-Z-S	3	0.60 - 0.94	4.38 1.88	3.86

MODEL NUMBER	NUMBER OF TIERS	CABLE/HOSE O.D. RANGE	CABLE CENTERS	CLIP LENGTH
W/STANDARD HARDWARE	A	B	C	D
T50-C111T-Z-S	1	0.31 - 0.59	4.25	2.75
T50-C121T-Z-S	1	0.60 - 0.94	4.38	3.86
T50-C211T-Z-S	2	0.31 - 0.59	4.25 1.31	2.75
T50-C221T-Z-S	2	0.60 - 0.94	4.38 1.88	3.86
T50-C311T-Z-S	3	0.31 - 0.59	4.25 1.31	2.75
T50-C321T-Z-S	3	0.60 - 0.94	4.38 1.88	3.86

MODEL NUMBER	NUMBER OF TIERS	CABLE/HOSE O.D. RANGE	CABLE CENTERS	CLIP LENGTH
W/STANDARD HARDWARE	A	B	C	D
T50-C11E-Z	1	0.31 - 0.59	4.25	2.75
T50-C12E-Z	1	0.60 - 0.94	4.38	3.86
T50-C21E-Z	2	0.31 - 0.59	4.25 1.31	2.75
T50-C22E-Z	2	0.60 - 0.94	4.38 1.88	3.86
T50-C31E-Z	3	0.31 - 0.59	4.25 1.31	2.75
T50-C32E-Z	3	0.60 - 0.94	4.38 1.88	3.86

## Intermediate Trolley with Cable Clamp

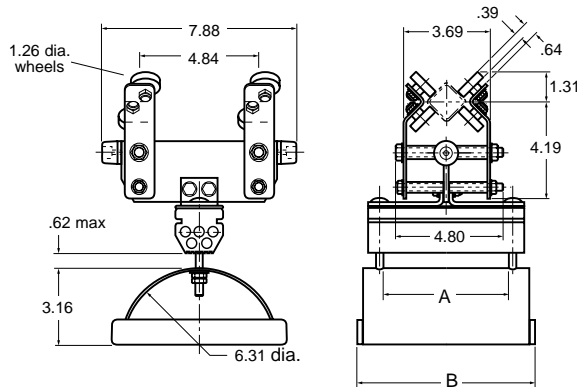

MODEL NUMBER	WINDOW WIDTH	OVERALL WIDTH
W/STANDARD HARDWARE	A	B
T50-M06-0602I-Z-S	2.62	4.31
T50-M06-0605I-Z-S	5.00	6.69

## Tow Trolley with Cable Clamp

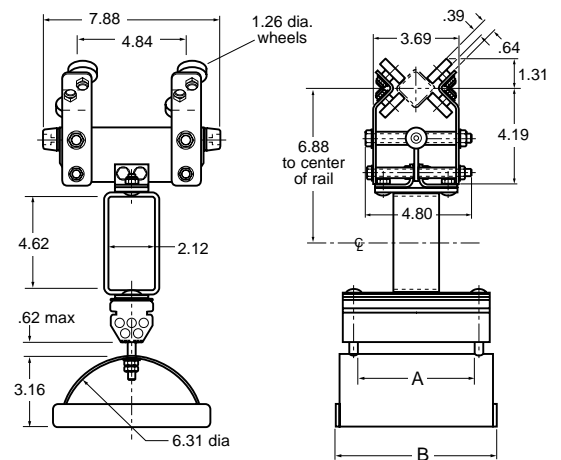

MODEL NUMBER	WINDOW WIDTH	OVERALL WIDTH
W/STANDARD HARDWARE	A	B
T50-M06-0602T-Z-S	2.62	4.31
T50-M06-0605T-Z-S	5.00	6.69

## End Clamp

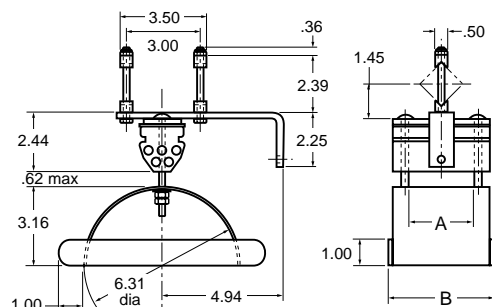

MODEL NUMBER	WINDOW WIDTH	OVERALL WIDTH
W/STANDARD HARDWARE	A	B
T50-M06-0602E-Z	2.62	4.31
T50-M06-0605E-Z	5.00	6.69

# Trolleys and Accessories for Flat Cable

T50 flat cable festoon systems are available in six sizes to handle a variety of cable sizes. Flat cables may be stacked provided stack height does not exceed window height (Dim E, below) and that weight of cables and trolleys does not exceed maximum capacity. All components orange baked polyester coating. All hardware zinc plated.

**Maximum load capacity: 50 lbs. per trolley.**

## Intermediate Trolley

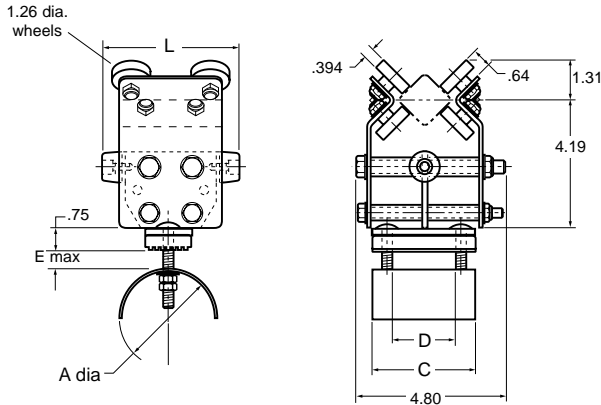

MODEL NUMBER W/STANDARD HARDWARE	SADDLE DIAMETER A	SADDLE WIDTH C	WINDOW WIDTH D	MAX. CABLE THICKNESS E	O.A. LENGTH L
T50-F02-1202I-Z-S	2.00	3.25	2.12	1.00	4.33
T50-F03-1202I-Z-S	3.12	3.25	2.12	0.60	4.33
T50-F03-2302I-Z-S	3.12	3.94	2.62	2.31	7.88
T50-F03-2305I-Z-S	3.12	6.31	5.00	2.31	7.88
T50-F04-2302I-Z-S	4.94	3.94	2.62	2.38	9.88
T50-F04-2305I-Z-S	4.94	6.31	5.00	2.38	9.88

## Tow Trolley

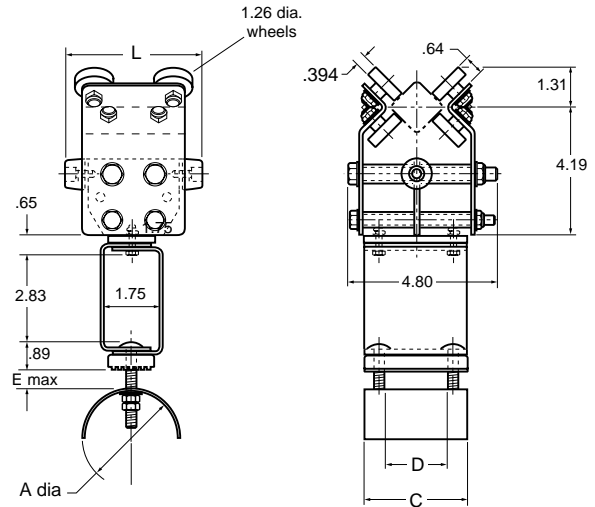

MODEL NUMBER W/STANDARD HARDWARE	SADDLE DIAMETER A	SADDLE WIDTH C	WINDOW WIDTH D	MAX. CABLE THICKNESS E	O.A. LENGTH F
T50-F02-1202T-Z-S	2.00	3.25	2.12	1.00	4.33
T50-F03-1202T-Z-S	3.12	3.25	2.12	0.60	4.33
T50-F03-2302T-Z-S	3.12	3.94	2.62	2.31	7.88
T50-F03-2305T-Z-S	3.12	6.31	5.00	2.31	7.88
T50-F04-2302T-Z-S	4.94	3.94	2.62	2.38	9.88
T50-F04-2305T-Z-S	4.94	6.31	5.00	2.38	9.88

## End Clamp

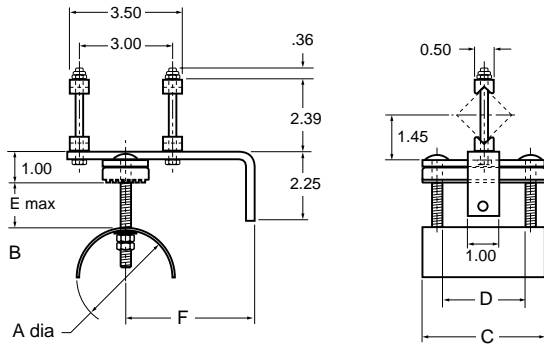

MODEL NUMBER W/STANDARD HARDWARE	SADDLE DIAMETER A	SADDLE WIDTH C	WINDOW WIDTH D	MAX. CABLE THICKNESS E	TO FIRST TROLLEY F
T50-F02-1202T-Z-S	2.00	3.25	2.12	1.00	3.17
T50-F03-1202T-Z-S	3.12	3.25	2.12	0.60	3.17
T50-F03-2302T-Z-S	3.12	3.94	2.62	2.31	3.94
T50-F03-2305T-Z-S	3.12	6.31	5.00	2.31	3.94
T50-F04-2302T-Z-S	4.94	3.94	2.62	2.38	4.94
T50-F04-2305T-Z-S	4.94	6.31	5.00	2.38	4.94



## Brake Products, Inc.

16751 Hilltop Park Place  
Chagrin Falls, OH 44023  
Phone: (888) 861-8777  
Fax: (440) 543-7963