

# Gleason Reel PDQ 300

## I-BEAM FESTOON SYSTEM

- **PRICED REASONABLY**
- **DELIVERED WHEN YOU NEED IT**
- **QUALITY THE WORLD EXPECTS FROM THE LEADER**

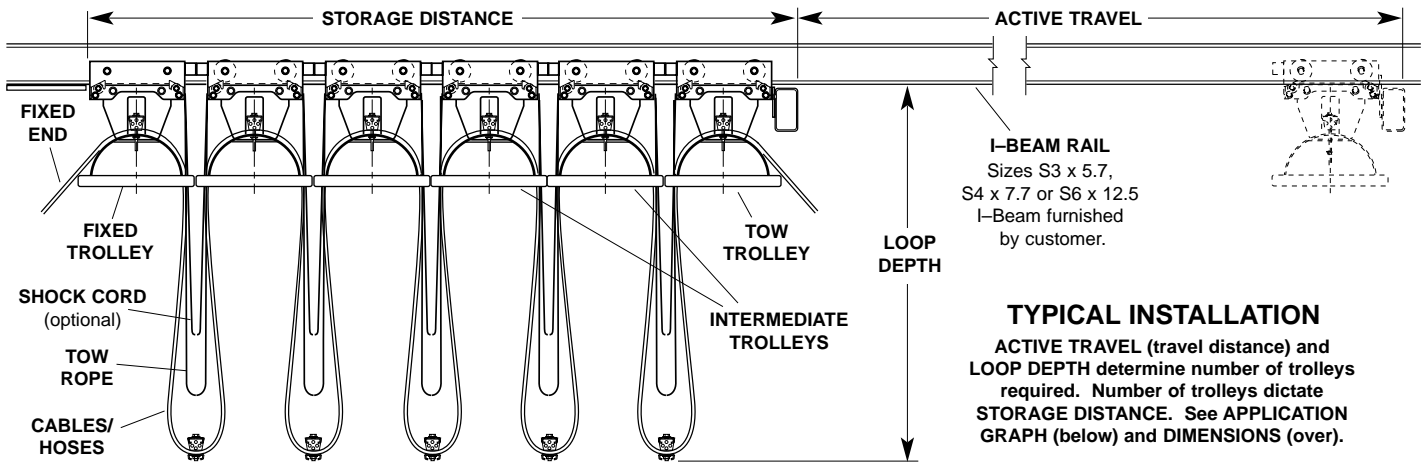

### A TROLLEY FOR LIGHTER FESTOONS—ECONOMICALLY PRICED, YET RUGGED

- 300 lbs. capacity per trolley at 400 fpm
- Trolleys have hardened 2.25" dia. steel wheels with oversized sealed ball bearings.
- Accepts either flat or round cable/hose.
- Single clamp design (two windows). Rubber compression clamp accommodates a variety of hoses/cables.
- Fits three sizes of I-beams: S3 x 5.7, S4 x 7.7, S6 x 12.5.
- Choice of three saddle dia. (6", 9", 12") in widths to 11".
- Fabricated steel construction—no castings.
- Baked polyester finish provides superior protection from corrosive marine environments.
- Two steel anti-lift rollers.

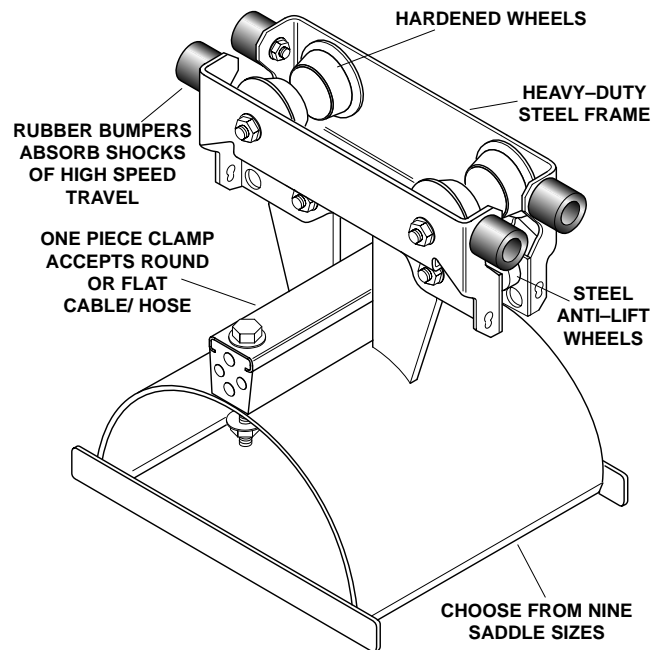

**APPLICATION GRAPH** (Reference only)

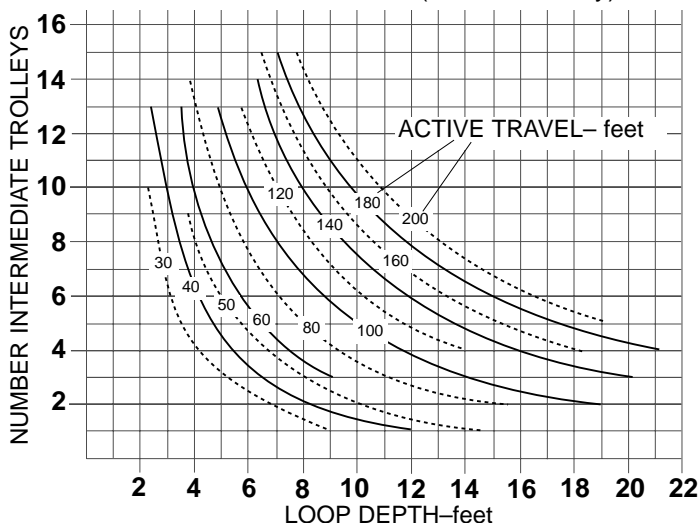

#### USING GRAPH AT LEFT

Graph at left is used to determine number of intermediate trolleys required for a given **ACTIVE TRAVEL** distance with a given **LOOP DEPTH**. To use graph, select appropriate active travel curve and a loop depth that will clear obstructions. Find point where vertical line (loop depth) intersects curve and follow across to find number of trolleys required. In addition, one fixed and one tow trolley are required. Consult factory or your local representative for more detailed application parameters.

## DIMENSIONS

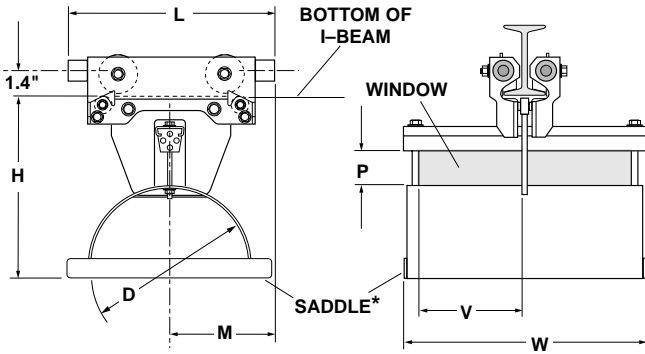

**INTERMEDIATE TROLLEY\***

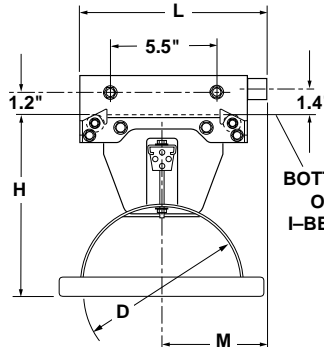

**FIXED TROLLEY\***

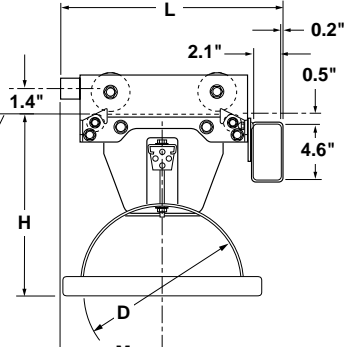

**TOW TROLLEY**

\*Nine inch saddle shown. Trolley for 6" saddle has four bumpers on one end only.  
12" trolley like above but with spacers between frame and bumpers.

SERIES 300 MODEL NUMBER	"D" SADDLE DIA.	"P" WINDOW HEIGHT	"V" WINDOW WIDTH	"H" BELOW I-BEAM	"L" OVERALL LENGTH	"W" OVERALL WIDTH	"M" SADDLE LOCATOR	WEIGHT lbs.
<b>INTERMEDIATE TROLLEY</b>								
PDQ-300-06-0102I-__	6.00	1.25	2.75	8.65	10.00	7.50	5.31	21
PDQ-300-06-0103I-__			3.75			9.50		
PDQ-300-06-0104I-__			4.75			11.50		
PDQ-300-09-0102I-__	9.00	1.19	2.75	10.45	11.38	7.50	5.69	23
PDQ-300-09-0103I-__			3.75			9.50		
PDQ-300-09-0104I-__			4.75			11.50		
PDQ-300-12-0102I-__	12.00	1.33	2.75	11.65	14.62	7.50	7.31	25
PDQ-300-12-0103I-__			3.75			9.50		
PDQ-300-12-0104I-__			4.75			11.50		

**FIXED TROLLEY** First trolley at fixed end of festoon system. Does not have rollers and is bolted in place.

PDQ-300-06-0102F-__	6.00	1.25	2.75	8.65	10.00	7.50	5.31	20
PDQ-300-06-0103F-__			3.75			9.50		
PDQ-300-06-0104F-__			4.75			11.50		
PDQ-300-09-0102F-__	9.00	1.19	2.75	10.45	10.38	7.50	5.69	22
PDQ-300-09-0103F-__			3.75			9.50		
PDQ-300-09-0104F-__			4.75			11.50		
PDQ-300-12-0102F-__	12.00	1.33	2.75	11.65	12.00	7.50	7.31	24
PDQ-300-12-0103F-__			3.75			9.50		
PDQ-300-12-0104F-__			4.75			11.50		

**TOW TROLLEY** Last trolley at moving end of festoon system. One required per system.

PDQ-300-06-0102T-__	6.00	1.25	2.75	8.65	12.68	7.50	5.31	22
PDQ-300-06-0103T-__			3.75			9.50		
PDQ-300-06-0104T-__			4.75			11.50		
PDQ-300-09-0102T-__	9.00	1.19	2.75	10.45	14.06	7.50	6.69	24
PDQ-300-09-0103T-__			3.75			9.50		
PDQ-300-09-0104T-__			4.75			11.50		
PDQ-300-12-0102T-__	12.00	1.33	2.75	11.65	15.69	7.50	8.32	26
PDQ-300-12-0103T-__			3.75			9.50		
PDQ-300-12-0104T-__			4.75			11.50		

### INDICATING BEAM SIZE

Model numbers above must be completed by indicating beam size as last digits using table below.

S3 x 5.7 = **S03** • S4 x 7.7 = **S04** • S6 x 12.5 = **S06**

**Example:**

PDQ-300-09-0102I-**S06**

### MINIMUM STORAGE DISTANCE

Minimum storage distance = sum of "L" dimension of all trolleys in system (see drawings above). This includes one fixed trolley, one tow trolley, and number of intermediate trolleys as determined on APPLICATION GRAPH (front). Minimum storage distance + active travel distance = total system length.

In your area contact:



## Brake Products, Inc.

16751 Hilltop Park Place  
Chagrin Falls, OH 44023  
Phone: (888) 861-8777 • Fax: (440) 543-7963